

An Introduction to

Business Blogging



How to use
business
blogging for
marketing
success

A publication of
HubSpot



Free Marketing Assessment:

Learn how an Inbound Marketing Strategy can help you reach your revenue goals.

Get Started Here





IS THIS BOOK RIGHT FOR ME?

Not quite sure if this ebook is right for you? see the below description to determine if your level matches the content you are about to view.

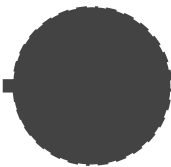

INTRODUCTORY

← — *This ebook!*

Introductory content is for marketers who are new to the subject. this content typically includes step-by-step instructions on how to get started with this aspect of inbound marketing and learn its fundamentals. After reading it, you will be able to execute basic marketing tactics related to the topic.

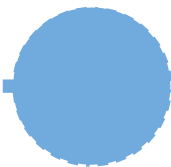

INTERMEDIATE

Intermediate content is for marketers who are familiar with the subject but have only basic experience in executing strategies and tactics on the topic. this content typically covers the fundamentals and moves on to reveal more complex functions and examples. After reading it, you will feel comfortable leading projects with this aspect of inbound marketing.



ADVANCED

Advanced content is for marketers who are, or want to be, experts on the subject. In it, we walk you through advanced features of this aspect of inbound marketing and help you develop complete mastery of the subject. After reading it, you will feel ready not only to execute strategies and tactics, but also to teach others how to be successful.

Share This Ebook!



www.Hubspot.com

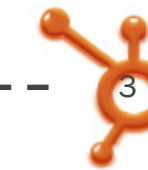

An InTRODUCTIOn TO BUSInESS BIOGGInG

by magdalena Georgieva

maggie Georgieva is an inbound marketing manager at Hubspot responsible for creating new offers, including ebooks and webinars. she has previously helped with Hubspot's email marketing program and the company's landing page creation and optimization. maggie is a prolific marketing blogger and has also written for publications like bostInnovation.com and *The St. Petersburg Times*.



FOLLOW ME ON TWITTER
[@MGIEVA](https://twitter.com/MGIEVA)

Share This Ebook!



www.Hubspot.com



Nearly **40%** of us companies use blogs for marketing purposes.

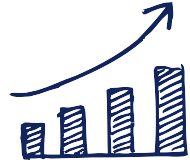

companies that blog have **55% more** website visitors.



B2C companies that blog get **88% more** leads/month than those who don't.



B2B companies that blog get **67% more** leads/month than those who don't.

the facts speak for themselves. marketing data clearly shows that blogging is a critical piece of the inbound marketing methodology and directly correlates to better business results.

but merely blogging won't dramatically transform your marketing. Your blog has to be well-optimized and promoted, and, most of all, rich with content. Frequency of blogging plays an important role in this equation, too. In fact, our research "[Lead Generation Lessons From 4,000 businesses](#)" shows that companies who blog 20 or more times in a month see the most return in traffic and leads.

A blog is a long-term marketing asset that will bring traffic and leads to your business. It introduces you as a thought leader in your space and allows you to earn people's trust. In this ebook we will walk you step-by-step through the blogging fundamentals and show you how to start reaping the benefits of this marketing channel.

Share This Ebook!





Hubspot's ALL-IN-oNe mArketING soFtwAre

... brings your [whole marketing](#) world together in one, powerful, integrated system.

- ✓ **Get Found:** Help prospects find you online
- ✓ **Convert:** Nurture your leads and drive conversions
- ✓ **Analyze:** measure and improve your marketing
- ✓ **plus** more apps and integrations

[request A demo](#)

[Video overview](#)

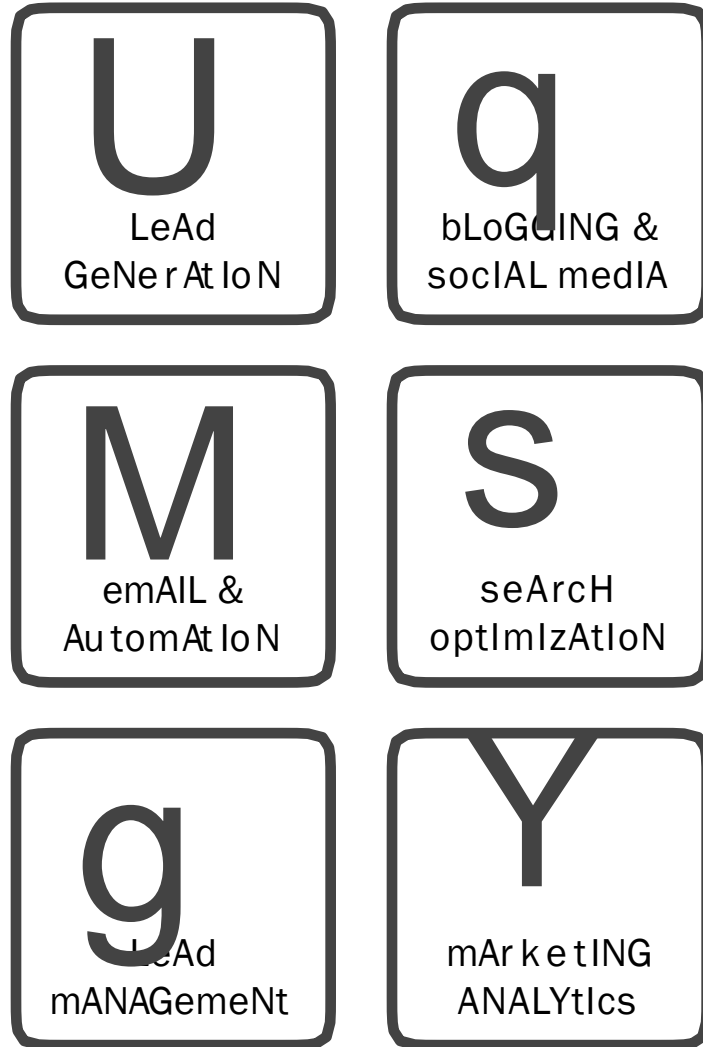

Share This Ebook!



COntEnTS

- [wHY YOU SHOUD HAVE A BIOG /8](#)
- [wHAT TO FInD COntEnt TO BIOG ABOUT /18](#)
- [HOw TO OpTIMIZe YOUR BIOG pOSTS /32](#)
- [HOw TO pROMOTE YOUR BIOG /48](#)
- [HOw TO MEASURE YOUR BIOG /58](#)
- [4 BUSInESS BIOGGInG BEST pRACTICES /70](#)
- [COncIUSION & ADDITIONAI RESOURCES /80](#)

Share This Ebook!



CHAPTER 1

WHY YOU SHOULD HAVE A BLOG

“The impact of business blogging extends to several major areas that marketers often overlook.”

we already shared with you some of the powerful facts around business blogging. Clearly, it is a marketing asset strongly related to attracting high-quality traffic and generating new leads. Yet the impact of business blogging extends to several major areas that marketers often overlook.

In this section we seek to draw the big picture that highlights the benefits of business blogging. we will elaborate on the different aspects in which your blog can bring you marketing success, from expanding your visibility on the web through creating a strong influence in the industry to effectively capturing new leads.

Share This Ebook!



www.Hubspot.com

First

First, business blogging helps you in respect to search engine optimization (seo). the more blog posts you publish, the more indexed pages you create for search engines to display in their results.

In other words, business blogging helps you rank in search engines and get found when people search for industry-specific products or services. Thus the blog enables you to attract organic traffic and familiarize people with your business.

Frequency Matters

In this framework, frequency of publishing blog posts matters a lot. [our research has shown](#) that businesses who blog 16 to 20 times per month get over two times more traffic than those who blog less than four times per month.

Optimize Your posts

the other essential element of attracting more traffic through organic search is optimizing your blog posts. make sure your blog titles incorporate industry keywords that people enter in search engines as they do research.

The Keyword post

what is the most important search engine keyword that you have not yet blogged about? take that keyword, and write a blog post about it. blogging is a great tool for driving [search engine traffic](#). take advantage of it!

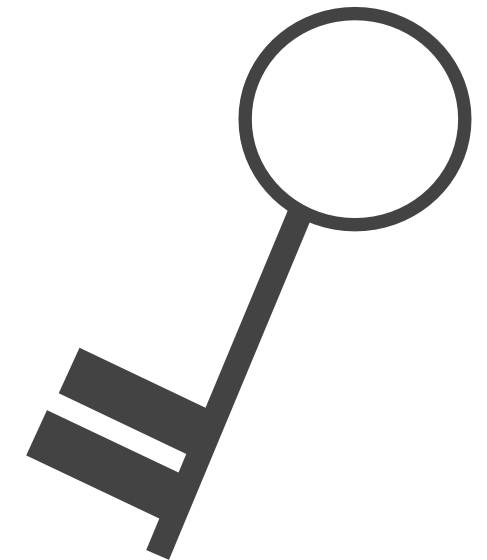

Case Study

[river pools and spas](#) publishes the most popular blog in the pool industry. when just getting started with blogging, the company knew it was best to target easier and very specific keywords. For example, “vinyl liner pools” was a long-tail term the company targeted.

second

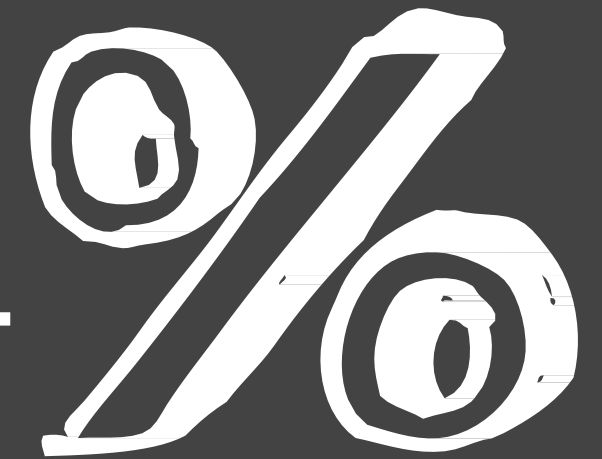

71%

say blogs affect their purchasing decisions.

second, your blog is an asset that introduces you as a **thought leader**. so if you have some industry specific information to share, a blog will help you earn people's trust and stay top of mind for many in your community.

Be a problem Solver

Name the biggest problem your customers have. with that problem in mind, write a detailed blog post that provides practical and non-product focused solutions. solve your customers' problems with content.

Build Thought leadership

use your blog as a platform to showcase your expertise on a given subject. Inject your knowledge of the industry into your blog posts and make a clear distinction between your brand and your competition.

Earn people's Trust

[In a recent survey](#) we asked respondents how much blogs affected their purchasing decisions. How often does one proceed to a purchase decision with blogging research? 71% of respondents said that blogs affect their purchasing decisions either somewhat or very much.

Make Blog CTAs Contextual

make sure you are matching the content you have written to the offer you want to highlight. In that way you create a seamless connection between the two and serve the reader who is ready to learn more about the topic. this is a very natural way of gauging interest and capturing leads. the contextual call-to-action is going to be much more appealing and have a much higher click-through rate to the subsequent landing page.

CTAs in Sidebar

one possible placement of calls-to-action is the sidebar of your blog. You can create banners to advertise some of your top-performing offers and add them around your blog for visitors to click on.

CTAs in Blog posts

You can place calls-to-action within the blog post itself, at the beginning, middle or end of the article. Also, don't forget to create **contextual** calls-to-action, by hyperlinking words to their according offers that you have.



t H I r d

third, a blog gives you real estate to place calls-to-action in order to generate leads. At this stage of the game you are trying to retain your blog readers and engage them further with your website and your content. so you might ask them to attend your webinar or to download a free guide that you have. [calls-to-action](#) introduce your prospects into the buying process and start qualifying them.



should You Have one or multiple blogs?

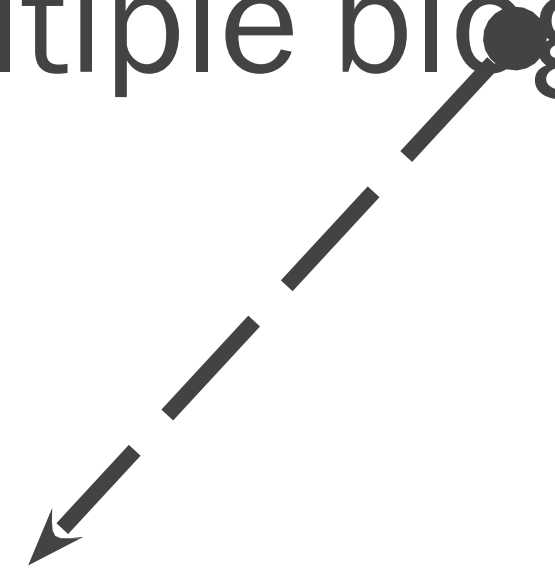
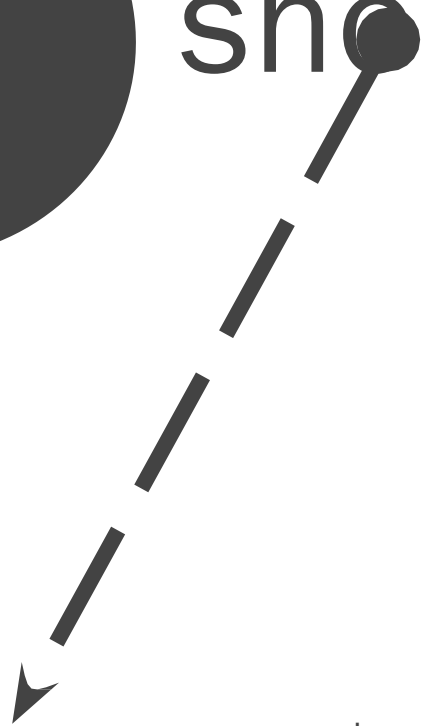

In some cases, when you are targeting niche audiences with very different needs, it might make sense to separate your business blogs. Yet it's always better to start with one blog and then consider further segmentation.

It's better if you integrate your efforts. the content creation and management process takes a tremendous amount of work and time. You need to minimize the work and maximize the profits.

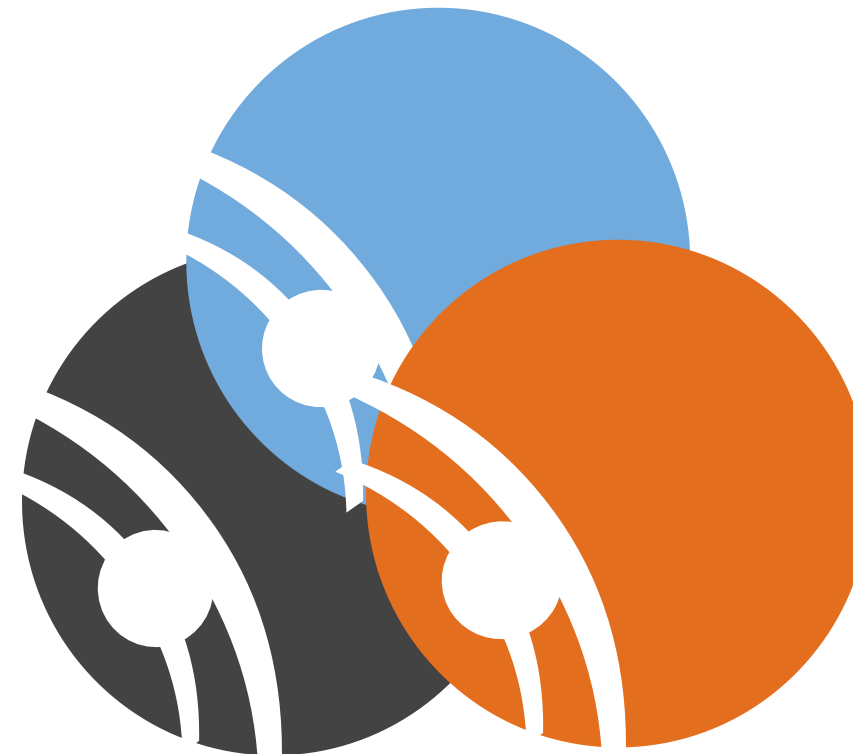

In general, you are able to separate content by tagging it with the appropriate keywords. so when people search for these keywords, they will arrive at the specific blog post and receive further information.

to be successful at this task, you need to have a clear understanding of the personas you are targeting.

Share This Ebook!



Share This Ebook!



“ Finding topics to blog about is one of the most frequent challenges marketers face. ”

CHAPTER 2

HOW TO FIND CONTENT TO BLOG ABOUT

by now you should be convinced in the [business value of blogging](#), but you have probably started wondering about what content you can possibly cover. what to write about?

welcome to the club! Finding [topics](#) to blog about is one of the most frequent challenges marketers face. we always recommend that you start by answering some of the most popular customer questions—reviewing industry trends, comparing prices of products or services in your industry or doing brief interviews with experts from your organization. these creative efforts seem time-consuming, don't they?

That is why in this section we will mention a few easy ways of finding the right content for your blog, from repackaging existing resources to involving others in the process and finding guest bloggers.

Share This Ebook!



www.Hubspot.com



REpACKAGE



start with something simple. do a thorough audit of existing content or internal communications. many times, you can take something that was maybe published internally, maybe you remove some proprietary information, and it becomes a great blog post because ultimately you're showcasing the inside of the brand and inside the organization. It should in a sense open up or showcase the inner workings of an organization. so what better way to start out with?

Next, reach out to others in your organization. whoever is one of your primary lines of communication with the outside world- whether that's customer service or sales- give them a pad of paper, and let's say for one day, every single time somebody asks them something, they should write down those questions. ultimately, that's going to give you kind of a really rich list.

Share This Ebook!



www.Hubspot.com

Share This Ebook!



www.Hubspot.com

BRAInSTORM

If you don't get outside of the company and also don't infiltrate other departments within the company, it's really easy to run out of content ideas very quickly. Instead, you should be constantly seeking new opinions, new insights.

Hold brainstorming sessions and consider creating a collaborative document to let people build on one another's ideas. If you are a small company, find peers out there or fellow bloggers who might be willing to participate in such brainstorm sessions. For instance, you can create a Facebook group with other people who are in a similar situation.

When you join a group that you can bounce ideas off, you'll find something really interesting: when you suggest a blog post to the brainstorming group, people will react if they are interested in the topic. If they don't react to it, it's not really going to drive that much interest for the larger audience either.

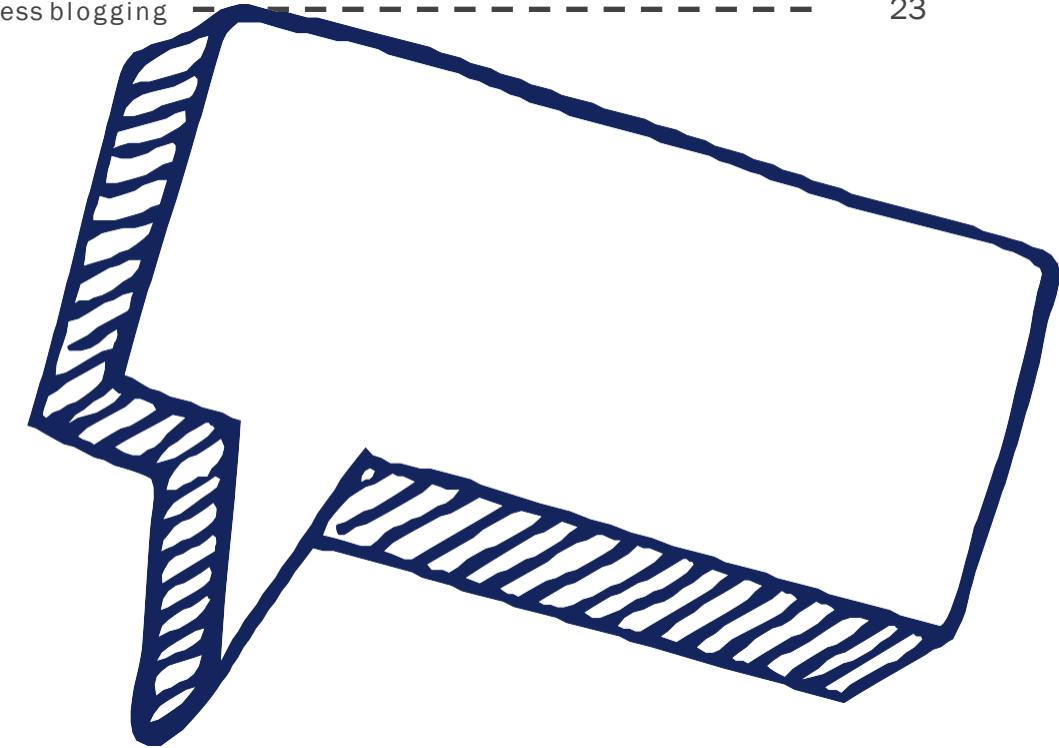

GUEST BLOGGING

Another method of finding content for your blog is by inviting other industry experts to write guest posts for you. Use your network to find people who might be interested in guest blogging. Be confident in pitching them benefits around guest blogging.

For instance, they will gain exposure beyond their normal readership and attract inbound links that can help them rank better in search engines. Guest blogging is also a great way to begin a comarketing partnership and build a strong relationship with industry influencers.

Share This Ebook!



www.Hubspot.com



Image credit: [brittneybush](https://www.brittneybush.com)

CURATION

“ Make sure you’re adding some layer of value for your reader by curating the information in the first place. ”

If you are going to curate information, make sure that you’re curating it to provide some type of values for your reader. don’t just curate content for the sake of doing it. Ask yourself these questions:

Are you saving the reader time by putting all these resources in one place?

Are you offering your own opinion and insight against what somebody else has said?

You need to make sure that you’re adding some layer of value for your reader by curating the information in the first place.

Most people are going to be really flattered if you want to share their content. And it’s a great opportunity to build a relationship with them. I think the simple guideline is do unto others as you would have done to yourself. Ask for permission before you curate some piece of content and make sure you credit the author. It’s really helpful when you’re giving links, that those links open in a new window.



Share This Ebook!



www.Hubspot.com

“You blog as often as you want people to pay attention to you.”

- Josh Hallett
director, Voce connect

when you are thinking about frequency of blogging, start doing the math backwards. If you need five new leads a month who you can follow up with, then how many new visits to your blog do you need?

“You blog as often as you want people to pay attention to you,” [said Josh Hallett in a Hubspot webinar dedicated to blogging](#). You need to do it a couple of times a week to once a day, he added. once you start publishing posts a few times a day, you will see a significant increase in traffic.

Another question you need to consider when creating your blogging schedule is setting expectations. You might blog once a week or twice a month, and that will be ok if your posts reveal great content that engages an active audience. but make sure you publish your posts around the same time so that you create anticipation in your readers.

Share This Ebook!



www.Hubspot.com

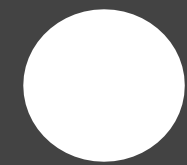

HOW OFTEN SHOULD YOU BLOG



“

An editorial calendar will help you maintain a healthy balance of content types. ”

”



In the [content creation](#) planning part, make sure you have a steady backlog of content, some of which addresses topics that are evergreen. In this way you are also considering the long-term effects of your blog.

try to build an editorial calendar which will help you map out things, have a general idea of your content and create a schedule. What is more, it will help you develop an approach. For instance, if you are trying to work hard on a specific keyword, you can focus on it for a month and then measure the results. Have you gone up in search for that keyword?

An editorial calendar will also help you maintain a healthy balance of content types--posts that are going to be short and popular and those that are meaty and comprehensive. You always need to have planned for something to go out at a certain time, and then be able to take advantage of opportunistic stories that allow you to post something around them. You also need to be agile and flexible in your content creation process.

“Optimize your writing to grab people’s attention and to rank well in search engines.”

CHAPTER 3

HOW TO OPTIMIZE YOUR BLOG POSTS

Frequency and quantity of blogging are certainly two factors that will impact your business results. However, you won’t get far without optimizing your blog posts.

You need to optimize your writing to grab people’s attention and to rank well in search engines. what is more, your blog posts should also introduce offers that can help your direct lead generation efforts. It’s a fairly simple concept – the more visitors you can attract to your blog, the more chances for conversion!

In this chapter of the ebook, we will look at ten different ways in which you can optimize your blog posts, from an [seo](#) perspective to a [lead generation](#) standpoint.

Share This Ebook!



1 Social Media Sharing Buttons

Give your blog content extended reach by including social sharing buttons (e.g. "Like," "share on LinkedIn," "tweet," etc.) on every post. this will encourage readers to share you content with their personal networks and expand its reach beyond your own connections.

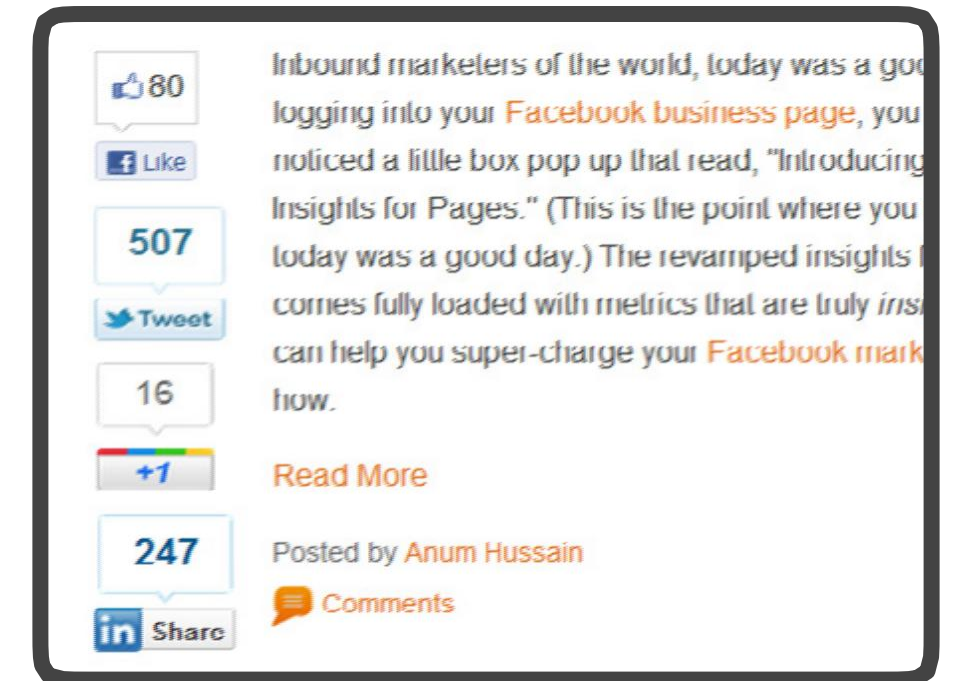

2 Compelling Images

Include an image that conveys what the blog post is about. this is appealing to readers and helps them go through the text-based content. A blog post that has some type of [visual](#) that's a photograph, a graphic or some type of infographic typically plays a little better than somethings that's purely text.

3 Eye-catching & Optimized Titles

Headlines are the most important element of your blog posts. While there are quite a few elements that make up a successful blog post, one of the best things you can do to capture readers' attention and entice them to view your post is to write an awesome blog title. Here are several title tips for eye-catching blog titles:

Be Clear & Direct

"[12 Quick tips to search Google Like an expert](#)" is an example blog title that tells readers exactly what they're going to get. do they want to learn how to conduct better Google searches? then they're going to read this post.

Drive Urgency

Another type of successful blog title is the one that creates a sense of urgency or importance. You want people to feel enticed to read a post when they first see the title.

How-tos

people love how-to's! most people who read blogs are reading them because they want to learn how to solve a particular problem. Indicate that your article will actually tell them how to do something they don't know how to do.

How not to

Just like people love to know how to do something, they also love knowing how not to do something wrong. people like reassurance that they're not doing something wrong. so use your blog to give them advice on how to fix common problems!

Be Controversial

controversial posts tend to spark a lot of discussion and debate, which also makes them spread quickly. so try making a blog title a bit controversial and see how your audience reacts to it.

that said, don't be controversial just for the sake of being controversial. make sure you present some solid, including well thought-out points within the post to back up your opinion.

Be Simple

try to keep your titles brief and concise. A long-winded title often sounds complicated and can lose a potential reader's interest. As a general rule of thumb, aim to keep your blog titles 8-9 words or [fewer](#).

Use numbers

Numbers are a great way to set expectations for a post. It tells readers exactly what they're going to get, and exactly how much of it. readers don't usually want to be kept guessing, so why not give it to them straight? write a blog post about some newly published industry research and make sure to include data points in your blog title.

newsworthy

we've found that a lot of relevant breaking news-type posts are successful in attracting viewership. Specifically, blog posts with the word "launch" in their title perform particularly well. use words that indicate the post's timeliness or newsworthiness directly in your title.

Be Sensational

sometimes you need a title that smacks you right in the face. It's dramatic. It challenges the reader. In other words, it make you want to click on the link? Like really badly?





4 Formatting Is Your Friend

In blogging, it is important to break text up in chunks. online reading is not like reading a physical book. the online reader needs to be able to immediately scroll through content to get to the subheaders and the bolded content and even bullet points. For example, here is how we have applied bullet points and different font sizes to the same content in order to make it more visually drawing:

BEFORE:

Hubspot is an all-in-one marketing software that helps your business get found online. It includes a suit of tools, such as keyword intelligence, blogging platform, email marketing, lead management, analytics and more. To find out more about Hubspot, start your 30-day free trial today.

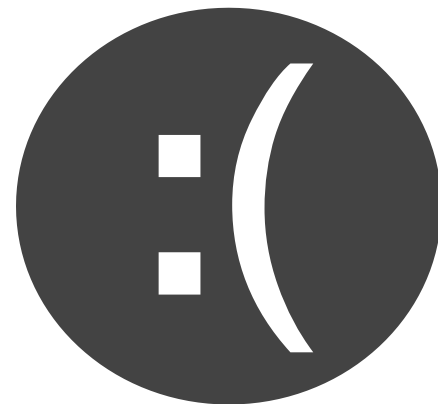

AFTER:

Hubspot is an **all-in-one** marketing software that helps your business get found online.

It includes a suit of tools, such as:

- keyword intelligence
- blogging platform
- email marketing
- Lead management
- Analytics

and more!

To find out more about HubSpot, start your **30-day free trial** today.



Share This Ebook!



Share This Ebook!





5 In-text Calls-to-Action

once you have built a blog readership, you can start making attempts to convert those visitors into leads. A well-constructed blog post should always include in-text links to other resources.

to maximize lead gen potential, why not point these links to landing pages for downloadable offers such as an ebook you've written, an upcoming or archived webinar, or other conversion opportunities like demo requests, free trials, etc.?



6 Sidebar Calls-to-Action

In addition to the individual blog articles you publish, the homepage for your blog can help generate leads in itself. the top of your blog as well as its sidebar are both prime real estate for ctA banners and buttons.

design some visually stimulating ctAs that link to landing pages for some of your best-performing offers. Feel free to also test and rotate different offers to make sure you're using this space for maximum lead generation power.

7 Make It Actionable

whether people found the [blog post through a search engine](#), an email, or a social network, they most likely clicked through to an article to solve a problem. what makes people share a post with others is the actionable insight it provides to solve a problem. provide clear takeaways and actionable steps in blog posts to ensure your idea resonates with readers.

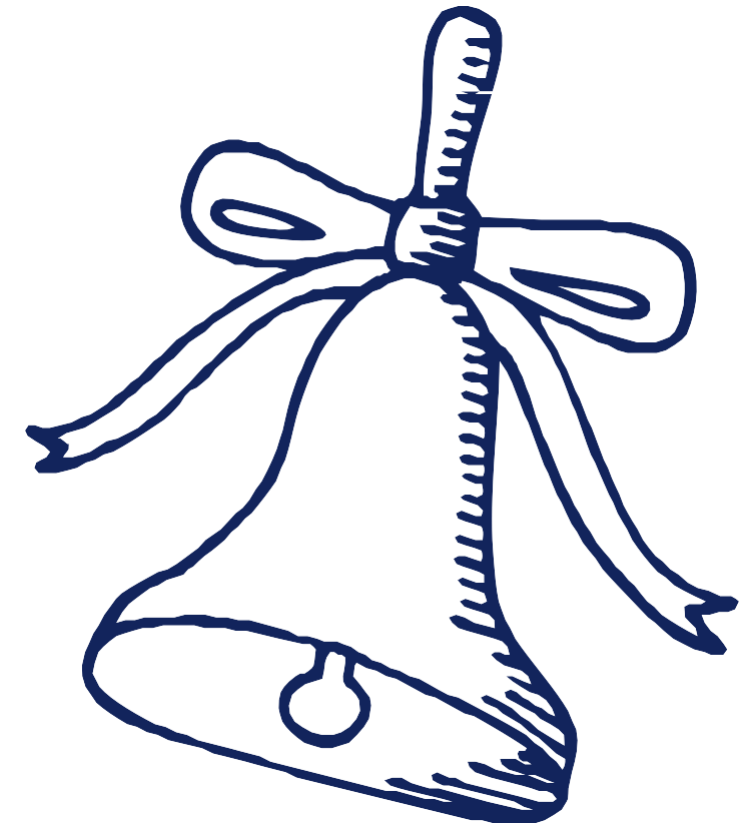

$$x + y - z \leq 2$$

8 Combined Relevance

metaphors are a timeless storytelling element. don't leave metaphors to novelists. they should be an active part of blog posts. comparing two seemingly different things and drawing connections between them is a valuable way to combine relevance and generate more interest in a subject.



9 Entertaining

Informative doesn't mean boring. Just because you sell sheet metal, doesn't mean your business blog can't also be entertaining. Have your shop crew make some fun and timely creations out of sheet metal and post an image or video of each new creation. Have someone outside your company review your blog post to check for entertainment.



10 Definitive

Great blog posts aren't meek or subtle. They are clear, direct, and definitive. Take a stand, make strong word choices, and don't waver on your advice. be the expert on your topic.



CHAPTER 4

HOW TO PROMOTE YOUR BLOG

“A blog is much easier to promote if it has been optimized for success.”

there are thousands of blogs out there. If you are convinced that yours should stand out from the rest, you should do the necessary work to promote it. promotion drives more traffic to your blog, increases your PR visibility and helps to establish you as an authority in your niche.

A blog is much easier to promote if it has been optimized for success. For instance, you need to be using compelling titles and images. You should also make it easy for your readers to spread blog posts across their networks. Let's look at the different ways in which you can gain exposure for your blog.

Share This Ebook!



www.Hubspot.com



2 Social Media Sharing

In this ebook, we already mentioned the connection between business blogging and social media sharing. this is definitely an essential dynamic for the promotion of your content. Just about every blog now has social sharing buttons to make it as easy as possible for visitors to share your content.

whenever you publish a new blog post, you should automatically publish it to the main social networks: twitter, Facebook, LinkedIn, and Google+. the most popular locations for buttons are above the content, below the content, or to the left of the content.

Share This Ebook!



1 Find Bloggers

A great starting point for promoting your blog is to leverage your existing connections and create new relationships. Reach out to influential bloggers in your industry and attract their attention through mentions on your blog and social media. Your goal here is to create an opportunity for them to share your blog posts across their network. what is more, you can create link-building opportunities that will prove essential in the accumulation of inbound links and how your blog posts rank in search engines.

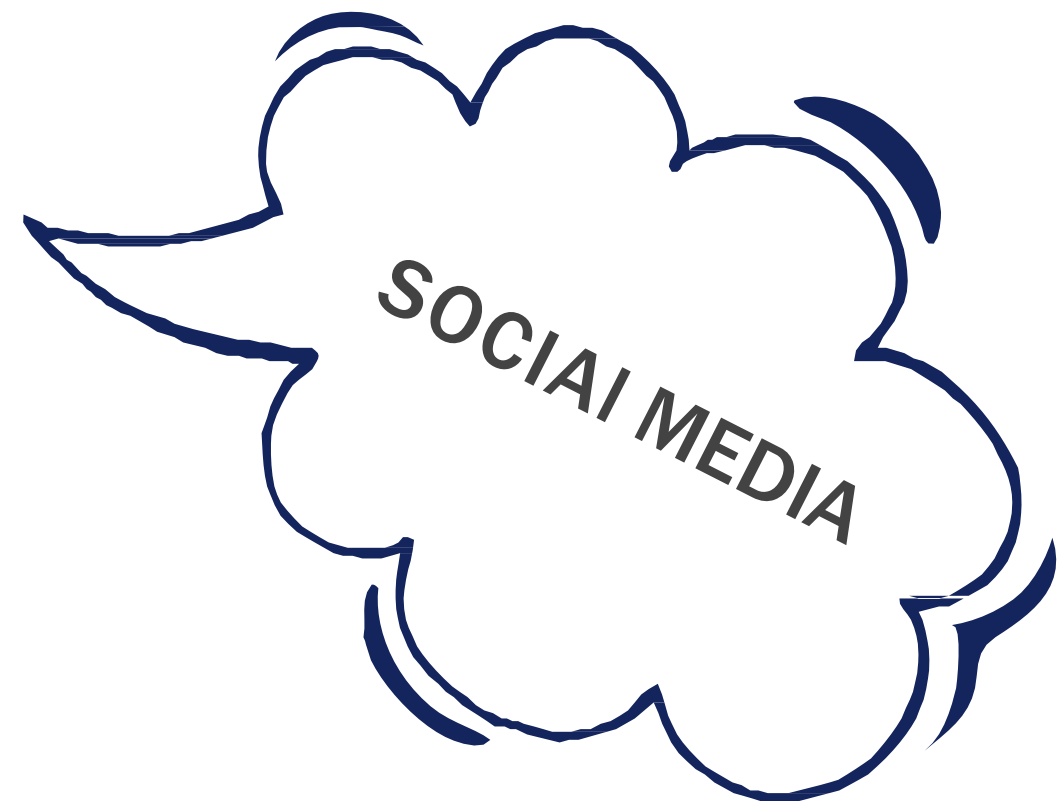

Share This Ebook!



CALLS-TO-ACTION

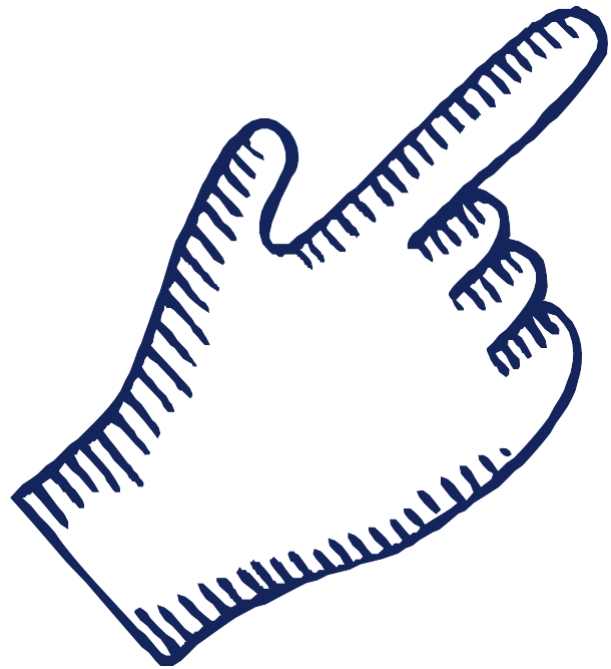

4 Events & presentations

If you are at an event and giving a presentation on a specific topic, you can refer the audience to your blog for further information. You can use a QR code to allow people to quickly and easily subscribe to your blog.

Share This Ebook!



www.Hubspot.com

3 website Banners

We cannot emphasize enough the power of calls-to-action in driving traffic to your blog. Consider placing calls-to-action on different pages of your website, such as your home page and *About Us* company page.

Carefully craft the language for the call-to-action. For instance, you can emphasize the number of people who are already subscribed to your blog and use a call-to-action along the lines of “45,000 people receive our new blog posts via email. Join them today!”



Share This Ebook!



www.Hubspot.com



6 Run a Contest

consider running a contest on your blog to attract more attention to it. come up with an entry system that requires other bloggers to link back to you. You can either have them publish a post on their blog, retweet a post from your blog, or 'like' your Facebook fan page in order to be eligible. Any one of these methods is sure to help expand your blog's reach and attract new visitors.

Share This Ebook!



www.Hubspot.com

5 Email Signatures

Your blog most likely covers a range of topics, all tailored to your marketing persona. so whenever you send an email, you can link to the awesome resources located on your blog. email signature can drive a surprisingly high amount of traffic to your blog.

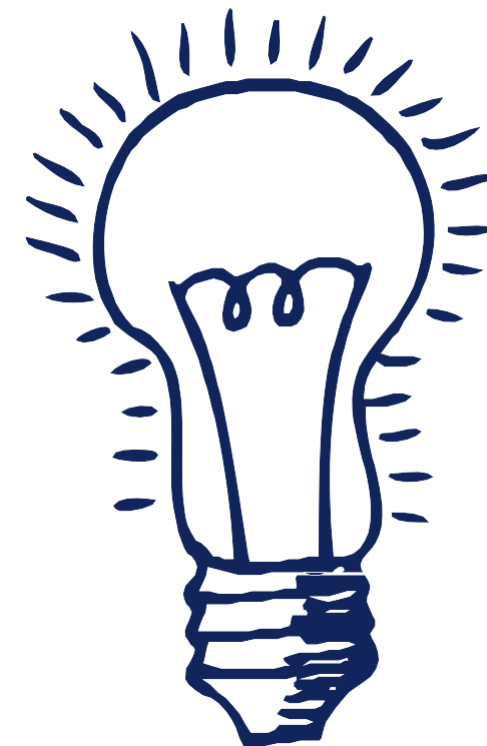

Share This Ebook!



www.Hubspot.com

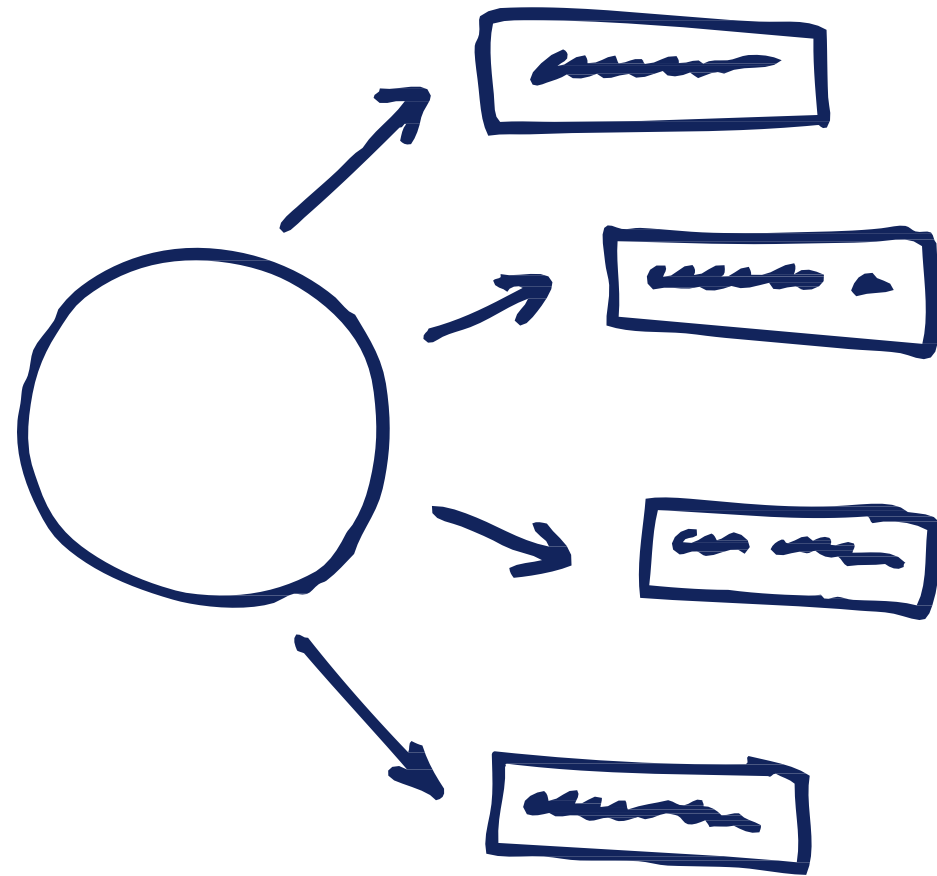

7 Blog Directories

blog directories present another opportunity for promoting your blog legally. there are hundreds of free blog directories out there. You'll want to make sure to submit your blog to at least the top 25-50 directories available. this can help you get more traffic and help with rankings as well because it creates [inbound links](#) to your blog.

8 Create a Video

create a short video to describe what your blog does and what its mission is. then, publish the video on YouTube and allow a different audience to find it. You can also create a controversial or funny video that links to the blog.



CHAPTER 5

HOW TO MEASURE YOUR BLOG

“ Business blogging without measuring results is a waste of time. ”

[business blogging](#) without measuring results is a waste of time. measuring the results of your business blogging efforts can save you time and make you more money! talk about a win-win.

when it comes to your business blog, there are a range of metrics that you could look at. In fact, the number of blogging metrics can get so large that to look at them all wouldn't leave much time for blogging, let alone other important aspects of inbound marketing.

Let's look at the most important metrics you need to keep an eye on to know how your business blogging is going.

Share This Ebook!



www.Hubspot.com

measuring Visitors

one of the most basic metrics is also one of the most important ones. Visits are the count of the people who actually read your blog content.

It's interesting to look at your total number of visits to measure the overall improvement of your blog. Yet a better way to look at this data is for visits by individual blog articles.

Looking at success factors for individual articles helps you better understand the type of information your target audience is looking for. Look at your five most successful blog posts. what do they have in common?

Share This Ebook!



www.Hubspot.com

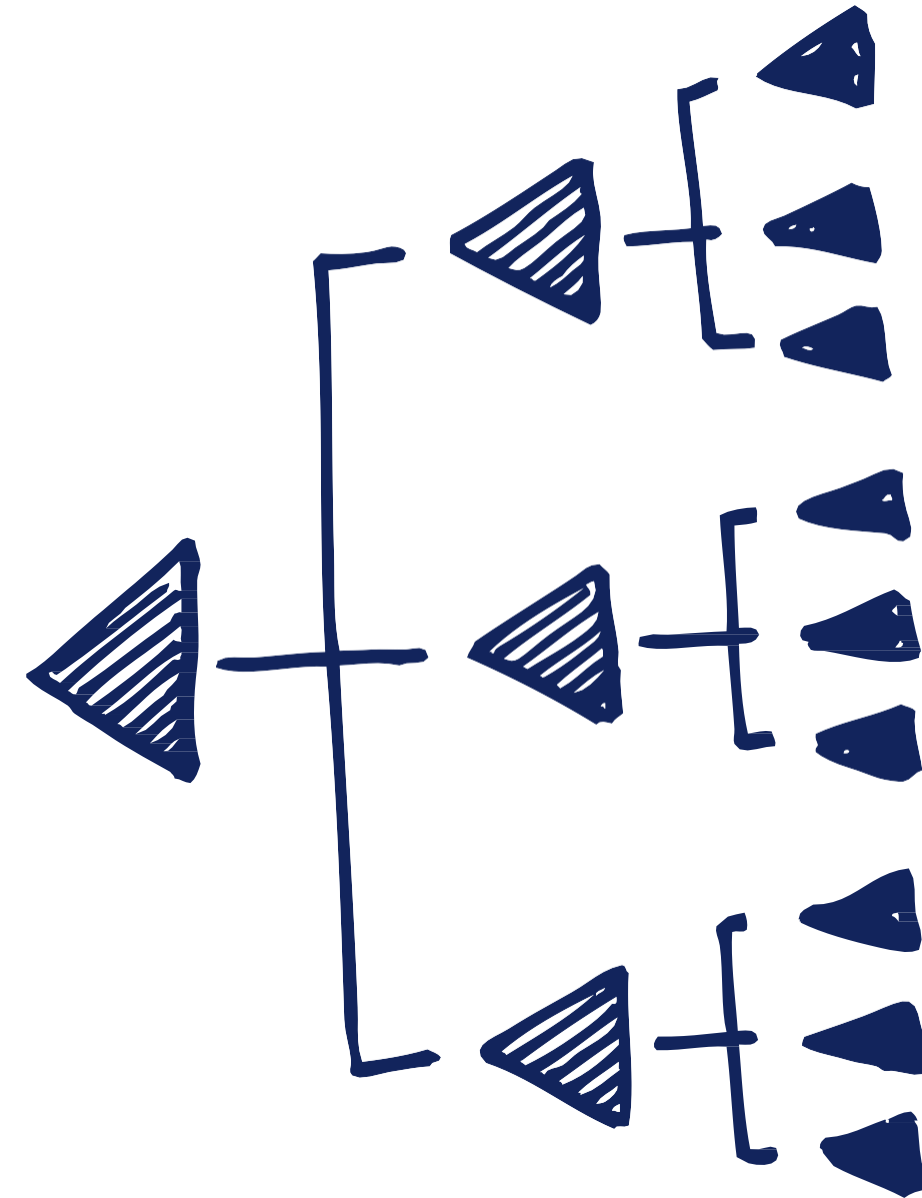

Share This Ebook!



www.Hubspot.com

measuring leads

If your business blog isn't generating leads for your business, you are missing a huge opportunity. Leads are what fuels the growth and success of your business. they are the true metric of a success business blog.

sometimes a post may not get a ton of visits but it generates lots of leads. without looking at the leads metric, marketers might easily dismiss the less viewed post as a failure. Yet that shouldn't necessarily be the case.

Look at the leads you generate from blog posts. Also examine at what rate those leads convert into customers compared to other marketing channels.



Subscribers count

It takes more than reading one blog article for a person to get an understanding of your expertise and credibility within your industry. Giving readers the opportunity to subscribe to your blog either via really simple syndication (rss) or via email is a common characteristic of a well-planned blog.

Looking at how many people subscribe to your blog provides a solid indicator of the quality and consistency of your content. Your subscribers act as the base readership of your content and can help spread it to others.

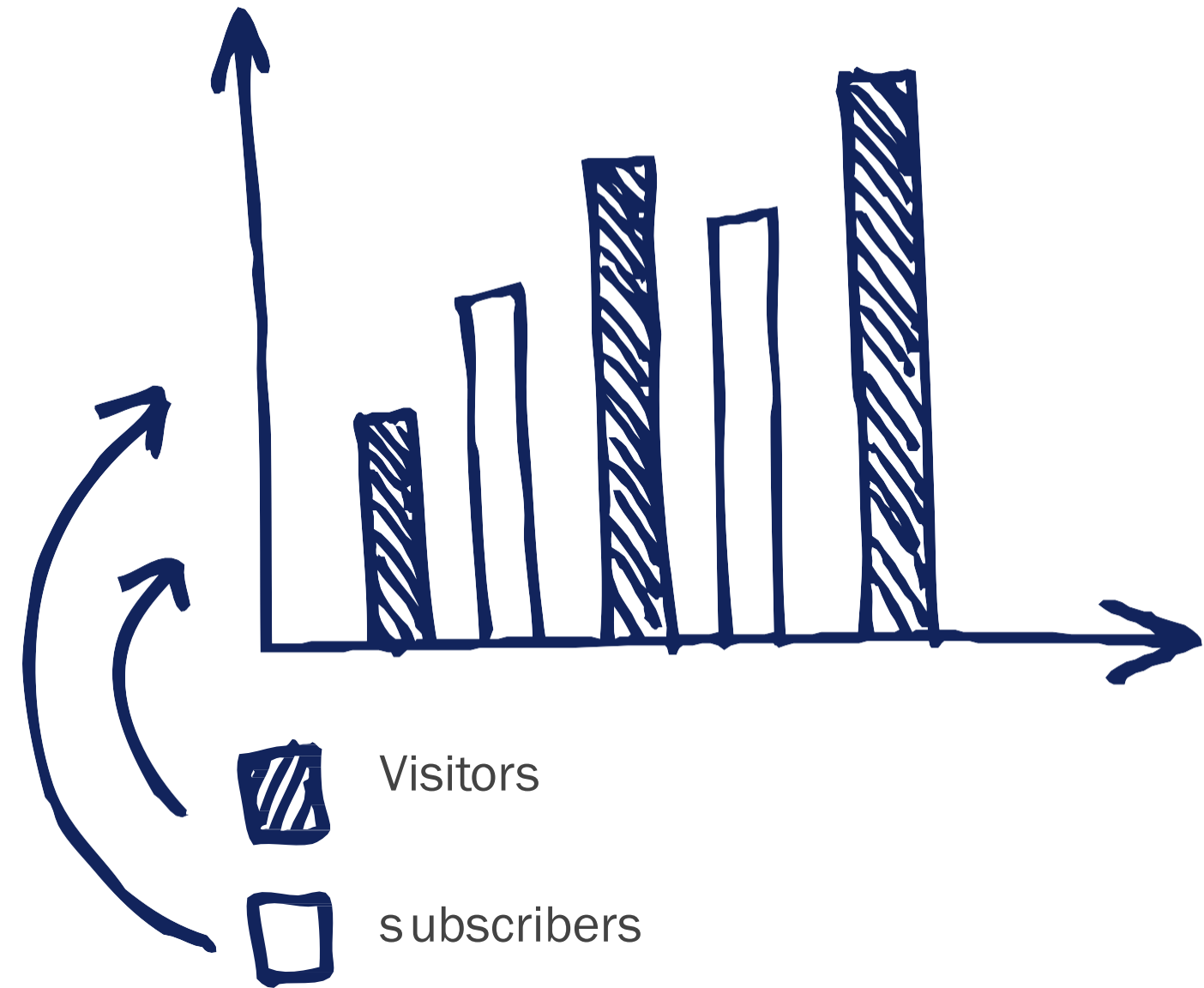

track Inbound links

when another website links to a page on your website, we call this an inbound link. search engines use inbound links as a method to determine how pages appear and rank in search engine results.

As blog posts are normally educational rather than product-centric, they are great at generating inbound links and subsequently search traffic.

It is important to look at how many inbound links each of your blog posts attracts. different types of blog posts and topics will vary in the number of inbound links they drive. Looking at these metrics for each post will enable you to have a well-balanced content strategy for your blog.

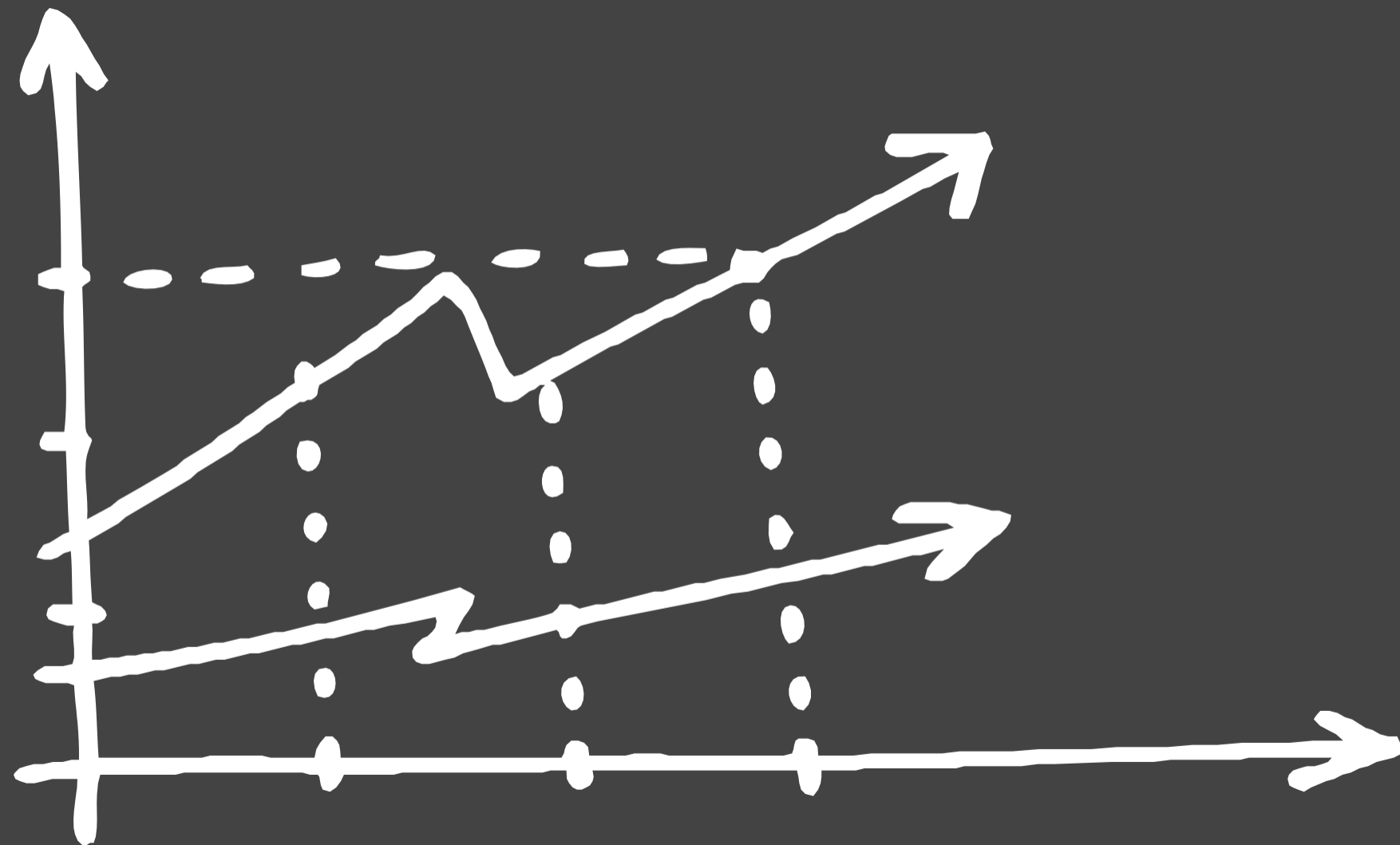

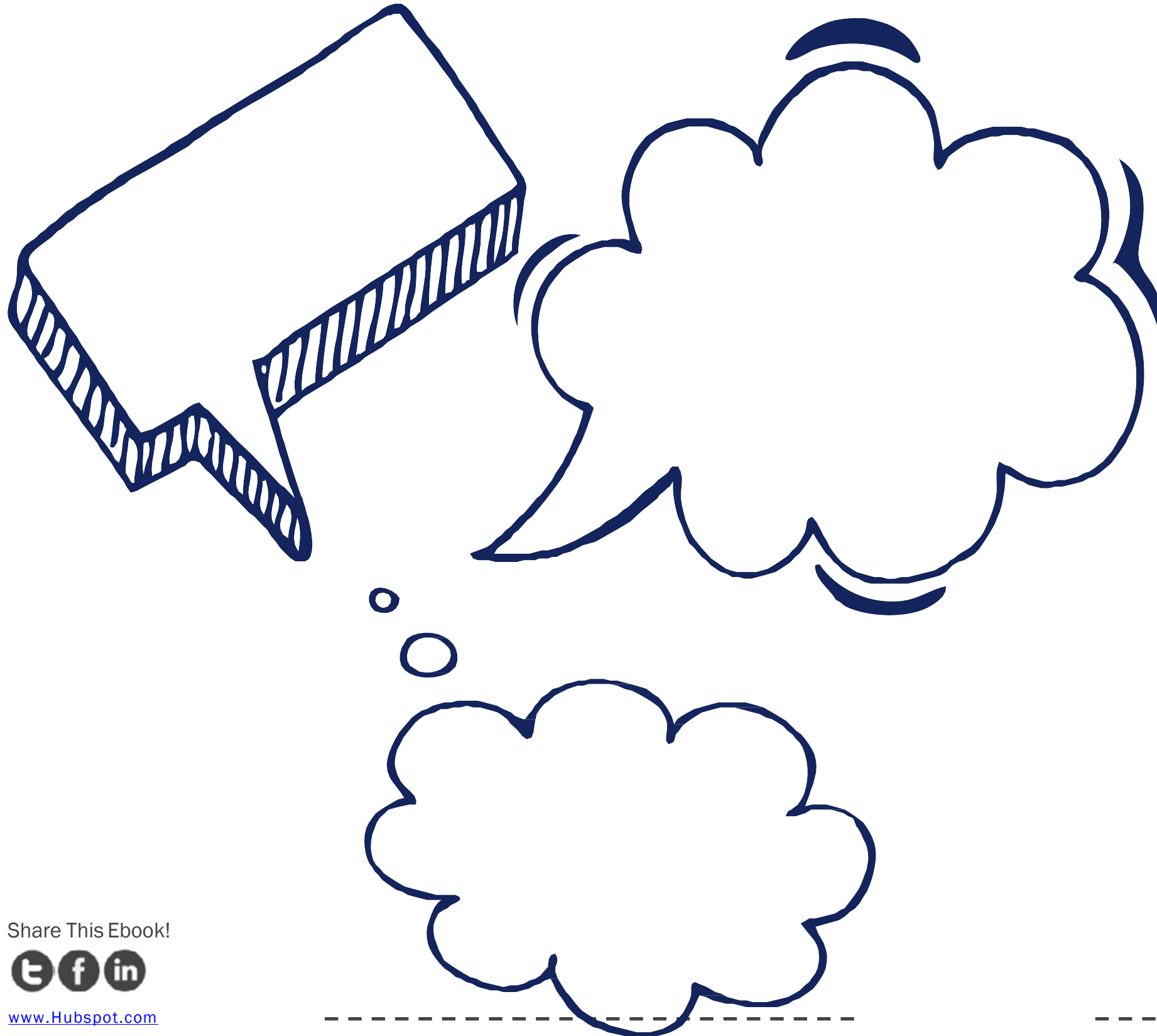

watch social media Shares

social media can be a key driver of short-term traffic. Look at the historic social media shares for your blog posts to determine which types of posts get the most short-term traffic from social media.

compare that data to number of visits or leads and see if there are any major inconsistencies. what could they be due to and how can you use them to your advantage?

Share This Ebook!



www.Hubspot.com

Share This Ebook!



www.Hubspot.com

“The challenge is to find the right blend of content for your audience.”

CHAPTER 6

FOUR BUSINESS BLOGGING BEST PRACTICES

Great business blogs have to walk a fine line: they have to create value for current and prospective customers while supporting a strategy that provides business growth.

business blogs are often measured by very different metrics than blogs that function as media outlets. the media business online is about impressions and clicks. However, if you are a b2b business blog and your goal is lead generation, then you really don't care about impressions. while one person may generate 100 impressions in a week for a media site, for a business blog, that same person is only going to account for one lead regardless of how often they view your content.

because business blogging has different goals, it also has some distinct best practices that distinguish it from individual and media blogs. However, some of the key principles of media and personal blogs are still very much important in business blogging. The challenge is to find the right blend of content for your audience.

Share This Ebook!



www.Hubspot.com



① Think like a Vertically Integrated publisher

You are not a business blogger, you are a vertically integrated online publisher. Your job isn't to put up an article or two each week. Instead, you have the same responsibilities that publishers in traditional media have; the only difference is that all of those responsibilities are tied directly to your business.

publishers have to create relevant content, determine the best methods to publicize their content to improve reach, and define advertising opportunities as well as manage them. As a vertically integrated publisher, you will do all of these things for your company to ensure that the content you create is valuable to prospective customers and is delivered in a way that can support lead generation for your business.

Share This



www.Hubspot.com

Share This Ebook!



www.Hubspot.com

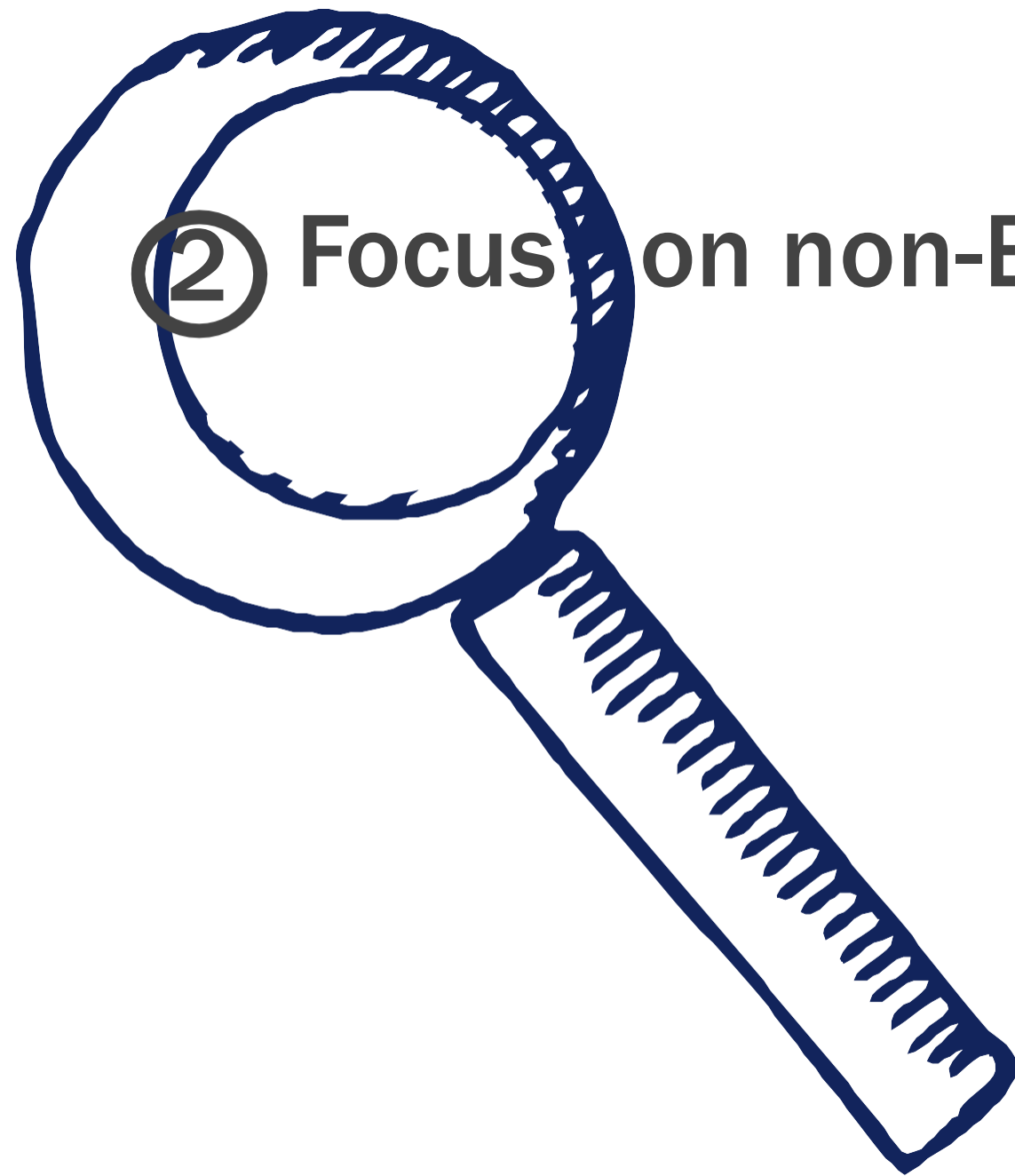

② Focus on non-Brand Keyword Content

readers don't want you to talk about your company on your blog, and this is great for your business. It is likely that if you have spent some time [optimizing your website](#), you rank well in search engines for your company name and related terms. However, business blogs provide the opportunity to build incoming traffic from non-branded keywords.

For example, if you are a manufacturer, instead of blogging about your company and products, you should be writing about industry best practices and answering common customer questions about higher level product issues. this content will not only help increase search traffic, but also drive better quality prospects to your business' website.

Share This Ebook!



www.Hubspot.com

Share This Ebook!



www.Hubspot.com



3 Ask Readers what They want

It is easy to get caught up in the type of information you think is interesting, but after business blogging for a few months, you'll experience the need to ask readers what they want.

Assumptions can often be wrong, so conduct a survey on your business blog as a way to obtain clear feedback from readers. Questions should address topics for future posts and types of content readers prefer (e.g. text, audio, video, etc.), and the survey should also include space for comments to give readers the opportunity to make their own, personalized suggestions.

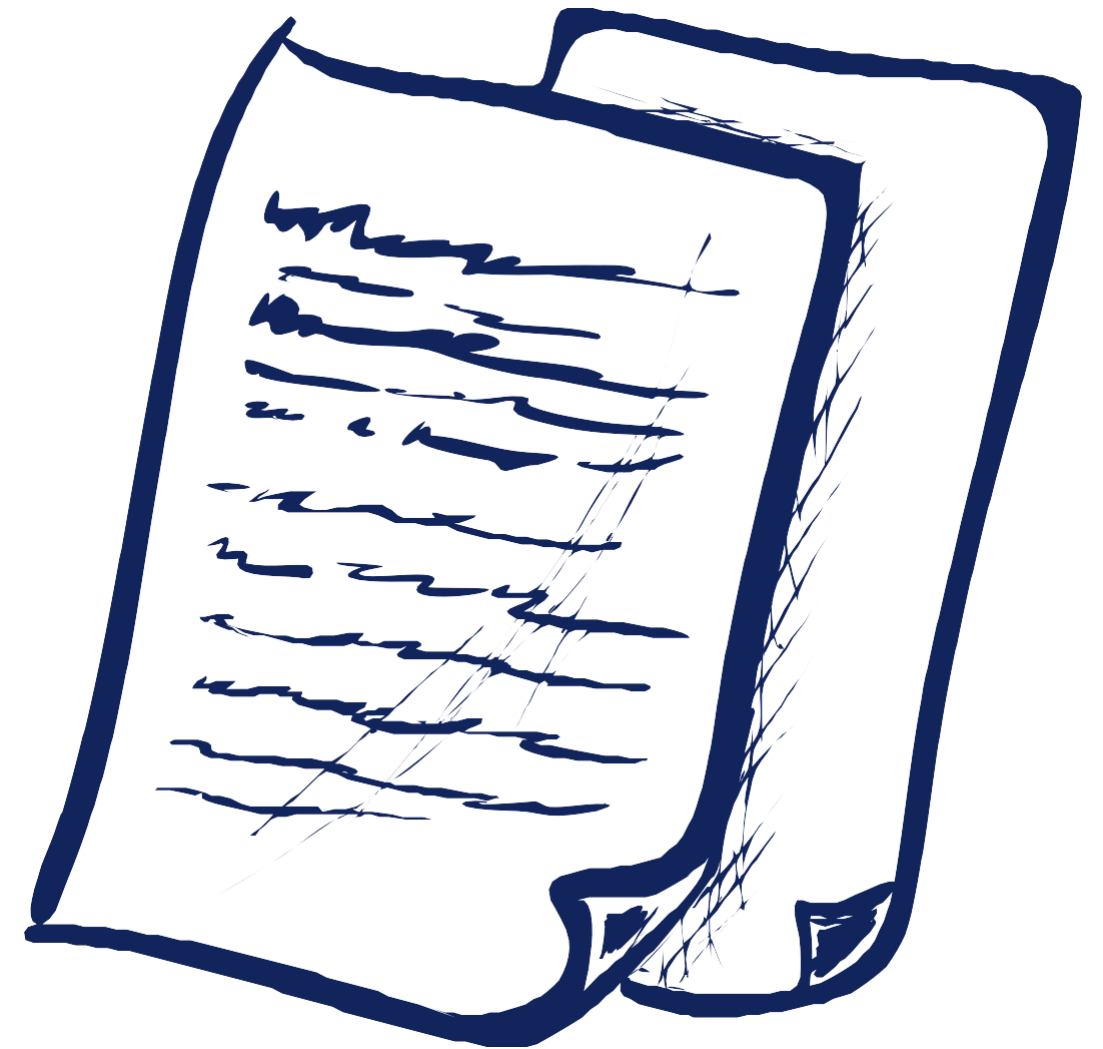

Share This Ebook!



www.Hubspot.com

Share This Ebook!



www.Hubspot.com

④ Connect Blog with website

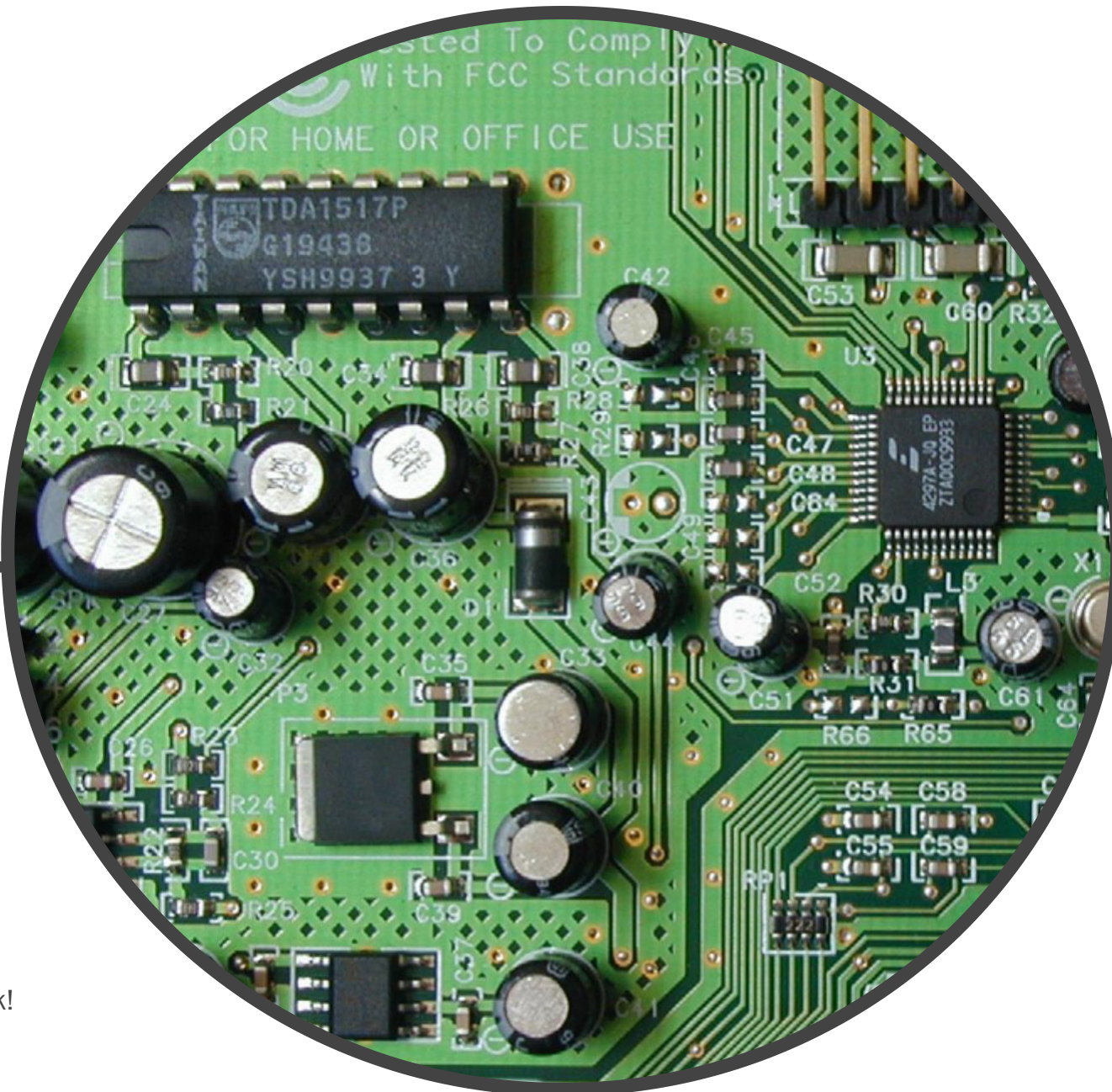

business blogs can be a major source of new traffic from search engines and social media. It is time to realize that a blog post may be the first thing a potential customer sees about your company. Having a blog as part of your corporate site, either as a subdomain (blog.yourdomain.com) or as a page (yourdomain.com/blog) is an important step to allow first-time visitors to easily learn additional information about your company.

It is also important to make sure the navigation and other design elements of your blog make it easy for users to find information about your company if they're looking for it.

Share This Ebook!



www.Hubspot.com

Share This Ebook!



www.Hubspot.com

“ Hope this ebook helped map out the direction you need to take in order to be successful at business blogging. ”

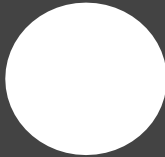

CONCLUSION & ADDITIONAL RESOURCES

business blogging is an essential part of online marketing. It helps your company gain exposure in front of a bigger audience and develop industry leadership. what is more, it directly impacts business results because it is strictly tied to an increase in organic search and referrals as well as robust lead generation.

As you embark on your business blogging journey, prepare for the work load tied to content management. build an editorial calendar and start adding to it some resources that you already have lying around, such as whitepapers, informative brochures and industry reports. we recommend that you involve a few more people in the content creation process.

Share This Ebook!



www.Hubspot.com

now, Bon Voyage!



Don't forget to optimize your blog posts by finding the right titles, tweaking formatting and including calls-to-action in the text. that is how you will start seeing business results.

After publishing a well-optimized post, don't just sit back and wait for it to generate conversations. promote it actively by making it easy for people to share the content with their network. make sure others in your organizations are also spreading the word.

Lastly, don't underestimate the power of business blogging metrics. they will show you which articles work and which don't. by looking at the number of views, leads and links your blog posts are drawing, you will gain a better understanding of your audience and their needs. such insights will guide you in your other marketing initiatives and help you develop an effective inbound marketing strategy.

Hope this ebook helped map out the direction you need to take in order to be successful at business blogging. Now bon Voyage!

GET BUSINESS FROM YOUR BIOG

Integrate your blog with the rest of your marketing to [generate the most leads and customers. Find out how in a custom demo of Hubspot's all-in-one software.](#)



Free Marketing Assessment:

Learn how an Inbound Marketing Strategy can help you reach your revenue goals.

Get Started Here



Share This Ebook!

